



This manual covers TopTech models:
TT-WCTO and WW160W



Applications Guide

Wireless Wire replaces 24V wiring. When the input module is energized with 24V on any terminal the paired terminal on the output module closes. There are also terminals on the output module that when energized with 24V will close the paired terminals on the input module.

Input module up to:

7 terminal inputs / 2 terminal outputs

Output module up to:

7 terminal outputs / 2 terminal inputs

Power Type

Hardwire (Common Wire)

Table of Contents

Page

Wireless Modules Quick Reference	2
Installation Tips	3-4
Subbase Installation	5
Wiring	6 - 7
Mounting the Wireless Modules	8
Specifications & Contact Info	9

A trained, experienced technician must install this product.

Carefully read these instructions. You could damage this product or cause a hazardous condition if you fail to follow these instructions.

Need Help?

For assistance with this product please visit <http://www.pro1iaq.com> or call Pro1 Customer Care toll-free at 888-Pro1iaq (776-1427) during normal business hours (Mon-Fri 9 AM - 6 PM Eastern)

Una versión española de este manual puede ser descargada en www.pro1iaq.com

Getting to know the Wireless Wire® Modules



- ① Terminal Lights
- ② Blue Indicator Light
- ③ Module Button



Important:

Both wireless modules must have 24VAC power connected on R and C. These modules can only switch 24VAC power. Wireless signal is one way from **Input Module** to **Output Module** for all terminals except **Input 1** and **Input 2**. Terminals **Input 1** and **Input 2** have a one way signal to **Output 1** and **Output 2**.

Connecting Wireless Wire®

1. Hold **Output Module Button** for 5 seconds.
2. The **Blue Indicator Light** will flash while waiting for a signal from the **Input** module.
3. Hold **Input Module Button** for 5 seconds.
4. The **Blue Indicator Light** will be continuously on to show communication has been established.



Notes on Wireless Wire®

When the **Y1** on the **Input Module** receives a 24VAC signal it sends a wireless command to the **Output Module** and it closes the **Output Module Y1**. This logic also applies to **Y2, W1, W2, G, B & O**.

When the **Input 1** on the **Output Module** receives a 24VAC signal it sends a wireless command to the **Input Module** and it closes the **Output 1** terminal. This logic also applies to **Input 2/Output 2**.

The **terminal lights** on the front of the module indicate when the associated relay is closed.

The **blue indicator light** will be on if communication is established and working.

The **blue indicator light** flashes when the unit is sending a signal.

The **blue indicator light** will be off if the module has not communicated for 1 hour or 24VAC has been lost.

All inputs will be turned off after 1 hour if the communication link is continuously lost.

PRO1 Tip

Visit our website at www.pro1iaq.com to learn more about our other wireless family of products

Wireless Modules - Basement Installation

ATTIC INSTALLATION
ON THE NEXT PAGE

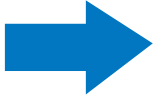

Wireless Range

Range between the WW160W Input module and the WW160W Output module is up to 100 feet with no obstructions and up to 50 feet in standard residential construction. To extend the range try placing the modules closer together and/or further away from large metal objects.

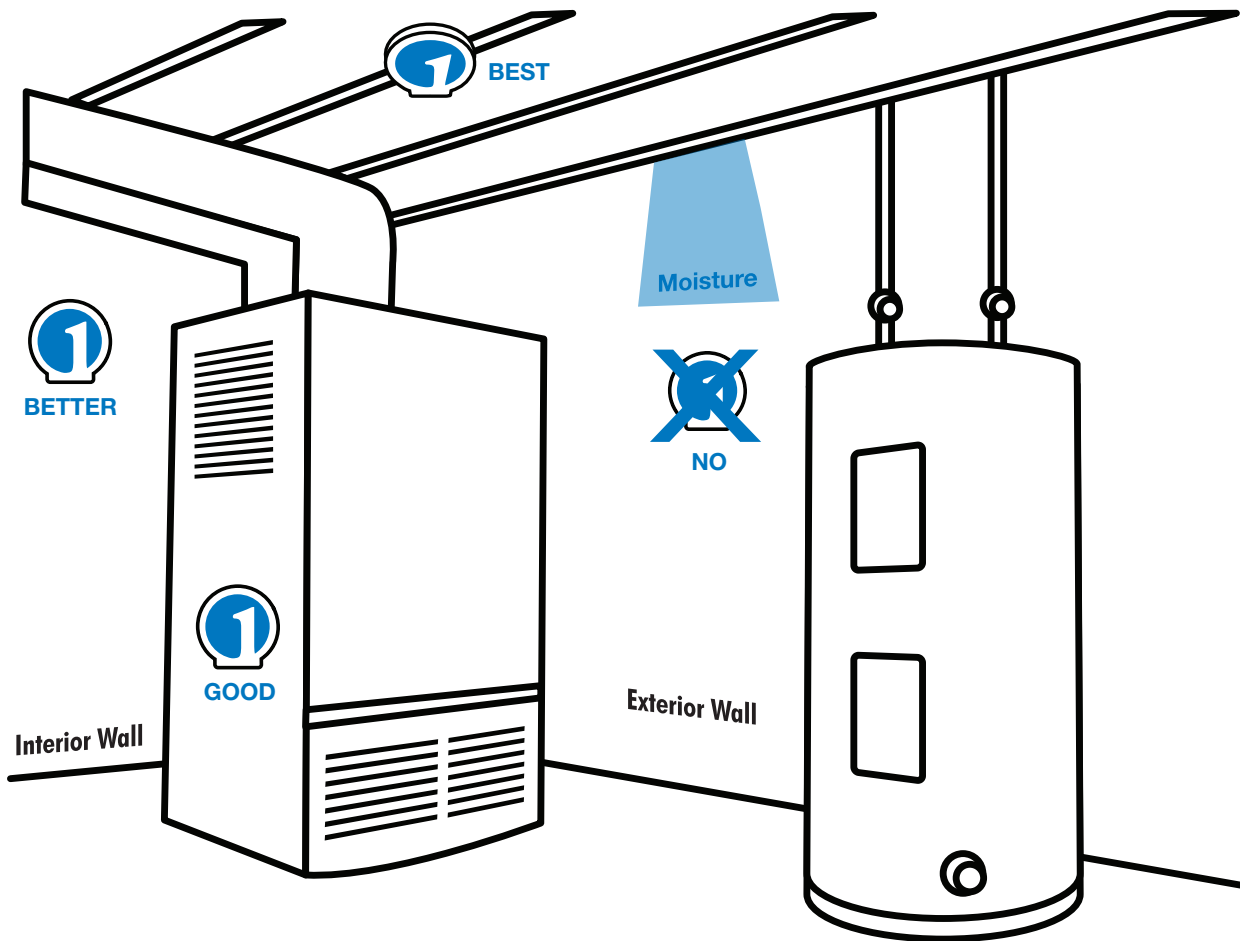

PRO1 Tip

Do not install the wireless modules in locations:

- That are behind a chimney
- Where temperature could exceed 140°F
- Where exposed to rain or snow
- Where exposed to extreme hot or cold

NOTE: The wireless modules are NOT weatherproof.

Wireless Module - Attic Installation

When performing an attic installation, instead of placing the wireless module in the attic, locate the closet nearest to the air conditioning unit. Then mount the wireless module high on the wall inside the closet or on the ceiling of the closet. This location will insure the wireless module is below the 140°F maximum ambient temperature specification.

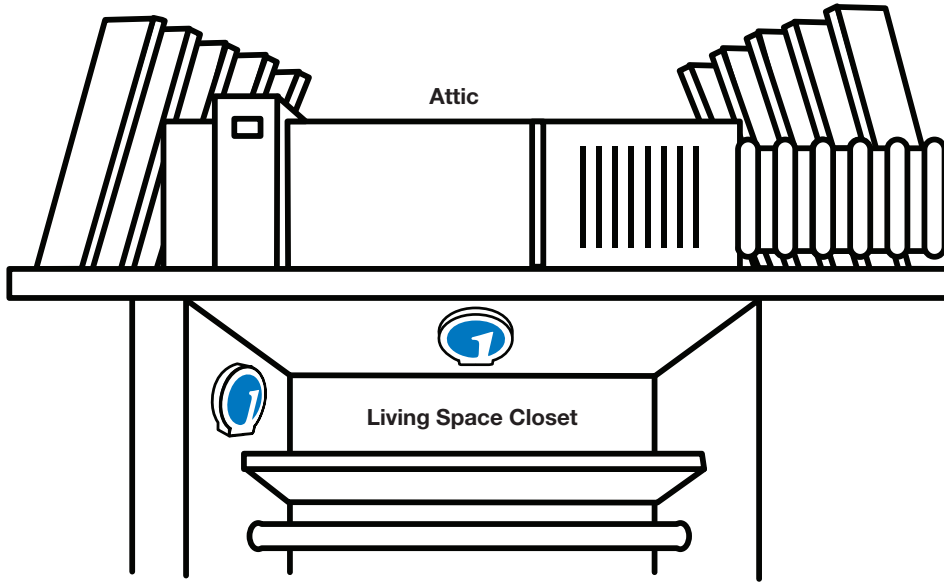

Wireless Module - Outdoor Installation

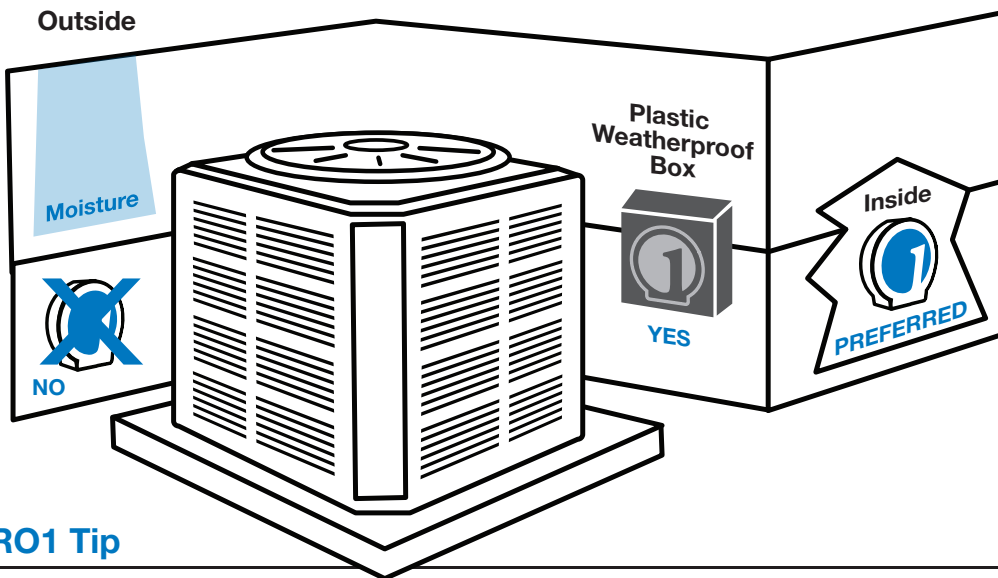

Note:

Installing the modules in a conditioned space is preferred.

Outdoor installations should only occur in climates that remain above freezing.

PRO1 Tip

Do not install the wireless modules in locations:

- That are behind a chimney
- Where temperature could exceed 140°F
- Where exposed to rain or snow
- Where exposed to extreme hot or cold

NOTE: The wireless modules are NOT weatherproof.

Mounting the wireless module subbase

For vertical mount put one screw top and one screw bottom.

For horizontal mount put one screw left and one screw right.

Wiring Note:

Wire the wireless module's subbase the same way you would wire a hardwired thermostat subbase.

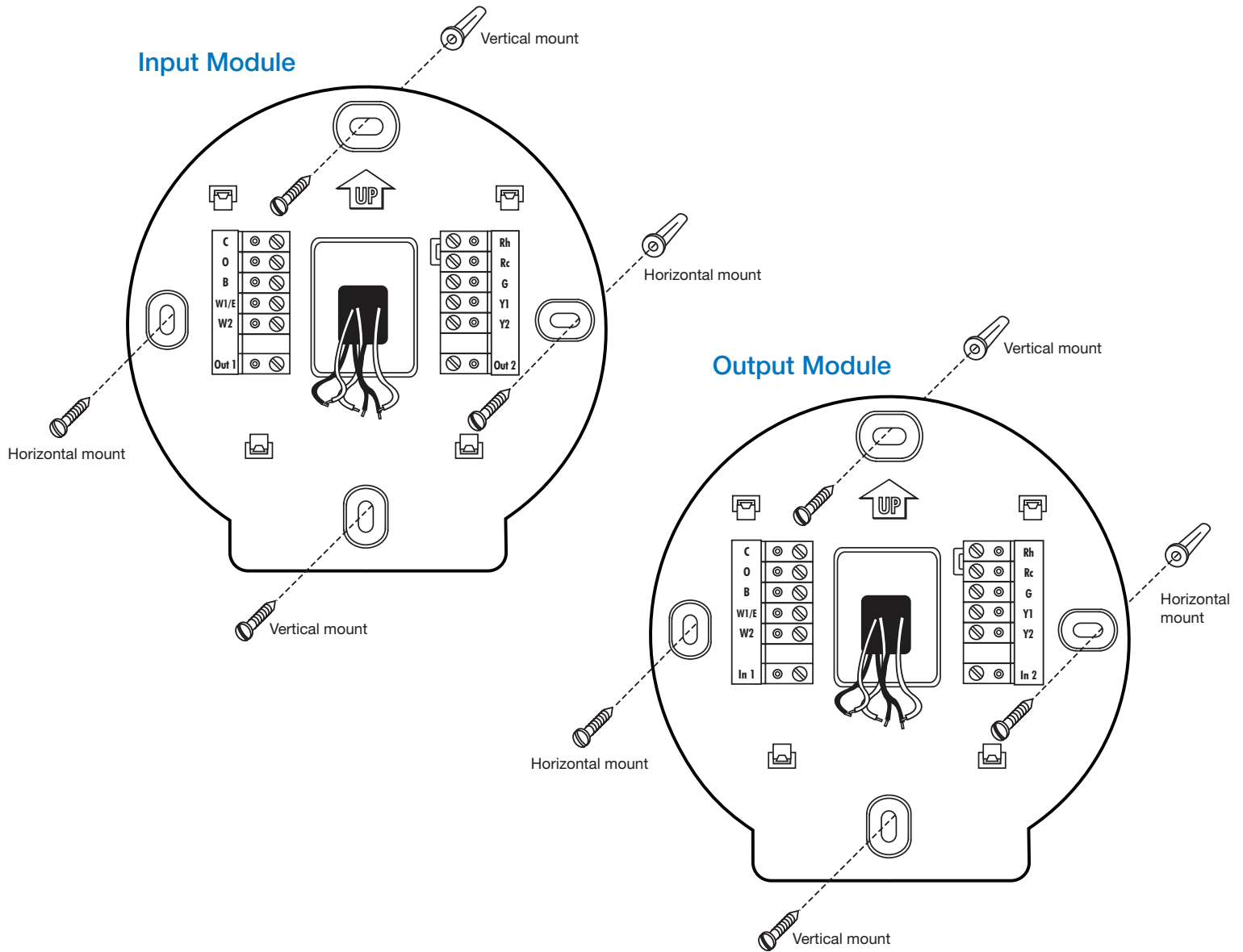

Note:

Both modules must be hardwired (C and R terminals connected to 24VAC power).

Thermostat To Equipment

- 1 Install the Input Module in a location that is convenient to wire the thermostat. Connect 24VAC to R and C on the input module.
- 2 Install the output module in a location that is convenient to wire to the system control board. (This is the board that normally has the thermostat wire connected to.) Connect 24VAC to the R and C on the output module.
- 3 Connect the terminals from the thermostat to the appropriate terminals on the input module. (Y1 to Y1, G to G, etc...)
- 4 Connect the terminals from wireless wire Output Module to system control board just like a thermostat.
- 5 Test the system.

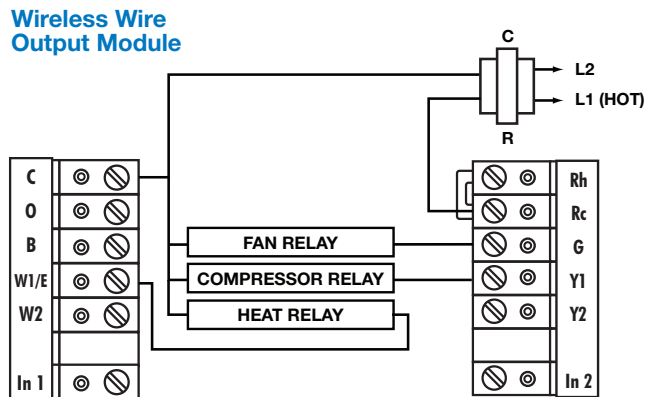
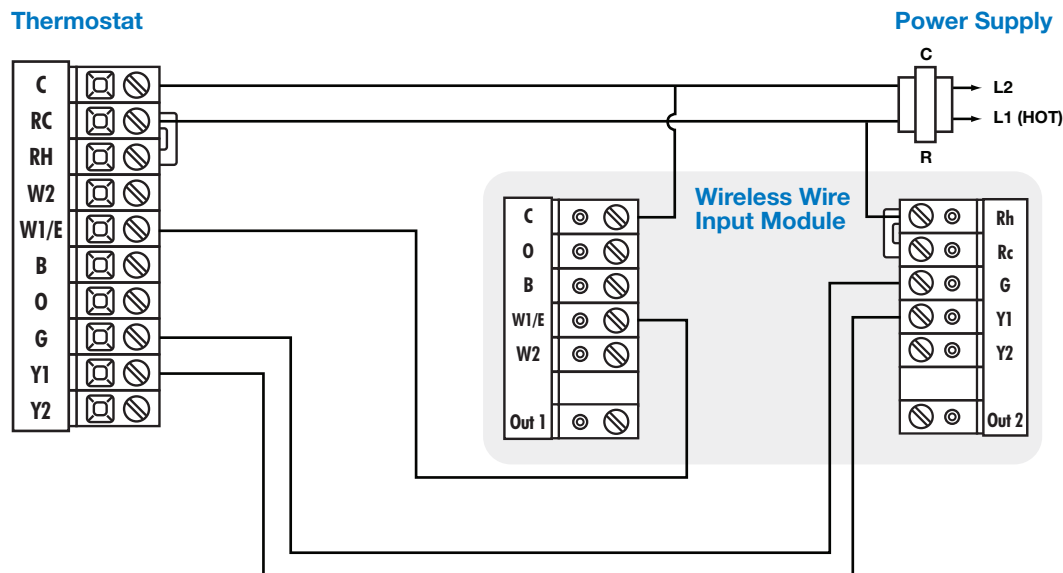

Wiring Note:
Wire the wireless module's subbase the same way you would wire a hardwired thermostat subbase.

Important:
Turn off power while wiring.

Air Handler to Multi-Stage Compressor

- ① Install the Input Module in a location that is convenient to wire to the system control board. (This is the board that normally has the wire from the condensing unit connected to it.) Connect 24VAC to the R and C on the output module.
- ② Install the output module in a location that is convenient to wire to the compressor relays.
- ③ Connect the terminals from the furnace control board to the appropriate terminals on the input module. (Y1 to Y1, etc...)
- ④ Connect the terminals from wireless wire Output Module to the compressor relays.
- ⑤ Test the system.

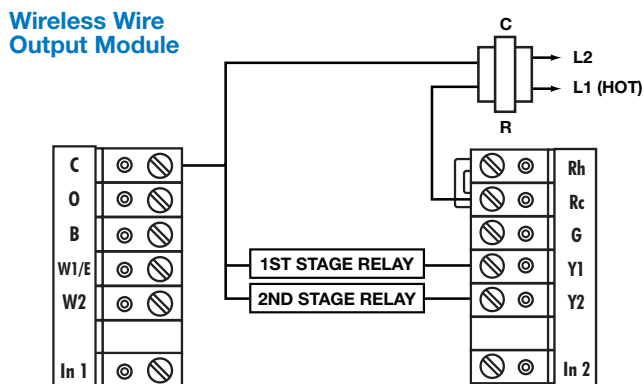
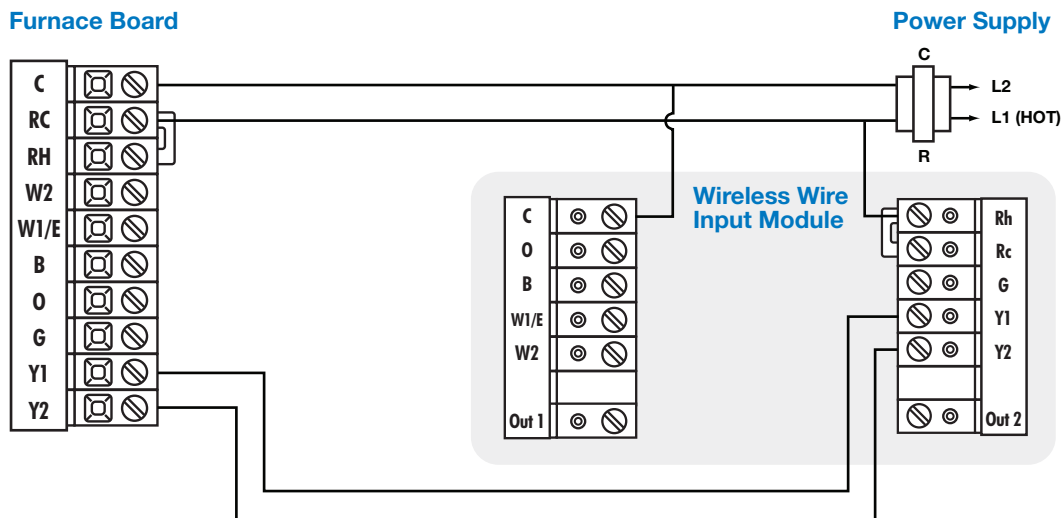

Wiring Note:
for Heat Pumps with a defrost cycle connect the defrost terminal to **Input 1** on the **Output Module** and connect **Out 1** on the **Input Module** to the appropriate terminal on the air handler.

Important:
Turn off power while wiring.

Mount the Wireless Modules

Align the 4 tabs on the subbase with corresponding slots on the back of the wireless modules. Then push gently until the thermostat or base module snaps in place.

Note:
The wireless modules can be wired from the back or the bottom.



Specifications

Load rating	1 amp per terminal, 1.5 amp maximum all terminals combined
Power source	18 to 30 VAC, NEC Class II, 50/60 Hz for hardwire (common wire)
Operating ambient	0°F to + 140°F (-18°C to + 60°C)
Operating humidity	90% non-condensing maximum
Frequency	916 MHz
Dimensions	4.4"W x 4.4"H x .75"D

Contact Us

Pro1 IAQ Inc.

1111 S. Glenstone
Suite 2-100
Springfield, MO 65804

Toll-free: 1-888-Pro1iaq (776-1427)

Toll Number (Outside the USA): 330-821-3600

Web: <http://www.pro1iaq.com>

Hours of Operation: Monday - Friday 9 AM - 6 PM Eastern